



FFBF280WX



75.25" x 27.63" x 24.75" (H x W x D)

ENERGY STAR qualified counter depth bottom freezer refrigerator with large capacity, deluxe interior, and white exterior; replaces FFBF280W

Highlights:

Counter depth for an easy fit in space-challenged kitchens

ENERGY STAR qualified performance ensures annual savings

Bottom freezer design offers easier accessibility

Deluxe interior includes dual crispers, glass shelves, LED lighting, and scalloped steel wine rack

Product Features:

ENERGY STAR qualified	Rated by the DOE to perform with more efficiency than federal standards require, saving your unit energy and you on higher utility costs
Bottom freezer	Thoughtfully designed unit saves energy waste by putting the freezer under the refrigerator to keep commonly used contents at eye level
Counter depth fit	Perfectly sized for smaller space-challenged kitchens
Combination frost-free/auto defrost design	Frost-free freezer and auto defrost refrigerator section for maximum energy savings
Adjustable glass shelves	Rearrange your refrigerator space to accommodate all shapes and sizes or remove shelves for a simple clean-up
Door storage	Store tall bottles and condiments right on the door for convenient access
Wine shelf	Scalloped steel shelf is ideal for keeping bottles safely in place
Two clear crispers	Twin crisper drawers offer the ideal storage conditions for produce, helping you to keep your fruits and vegetables separated
Interior LED light	Energy efficient LED light automatically illuminates when the refrigerator door is opened



FFBF280WX Specifications:

Overview	
Height	75.25"
Width	27.63"
Depth	24.75"
Depth with Handle	26.75"
Depth with door at 90°	52.38"
Capacity	13.81 cu.ft.
Defrost Type	Frost-Free/Automatic
Door	White
Cabinet	White
US Electrical Safety	ETL
Canadian Electrical Safety	ETL-C
Energy Usage/Year	412.0kWh/year
Amps	1.5
Voltage/Frequency	115 V AC/60 Hz
Weight	189.0 lbs.
Shipping Weight	200.0 lbs.
Parts & Labor Warranty	1 Year
Compressor Warranty	5 Years
Refrigerator-Freezer	
Door Swing	RHD
Reversible	Yes
Crisper Qty	2
Crisper Finish	Transparent
Crisper Cover	Glass
Refrigerator - Interior Height	40.5"
Refrigerator - Interior Width	24.25"
Refrigerator - Interior Depth	18.25"
Refrigerator - Capacity	10.77 cu.ft
Refrigerator - Shelf Type	Glass and Scalloped
Refrigerator - Shelf Qty	4
Refrigerator - Full Door Shelves	4
Freezer - Interior Height	22.0"
Freezer - Interior Width	21.5"
Freezer - Interior Depth	15.25"

Freezer - Capacity	3.04 cu.ft
Adjustable Shelves	Yes
Wine Bottle Shelving	Yes
Interior Light	Yes
Thermostat Type	Dial
Fan Type	Interior
Freon	R600a
Freon Amount	1.94
High Side PSI	435.0
Low Side PSI	104.0
Level Legs	2
Interior Drawers	Yes
Drawer Qty	2

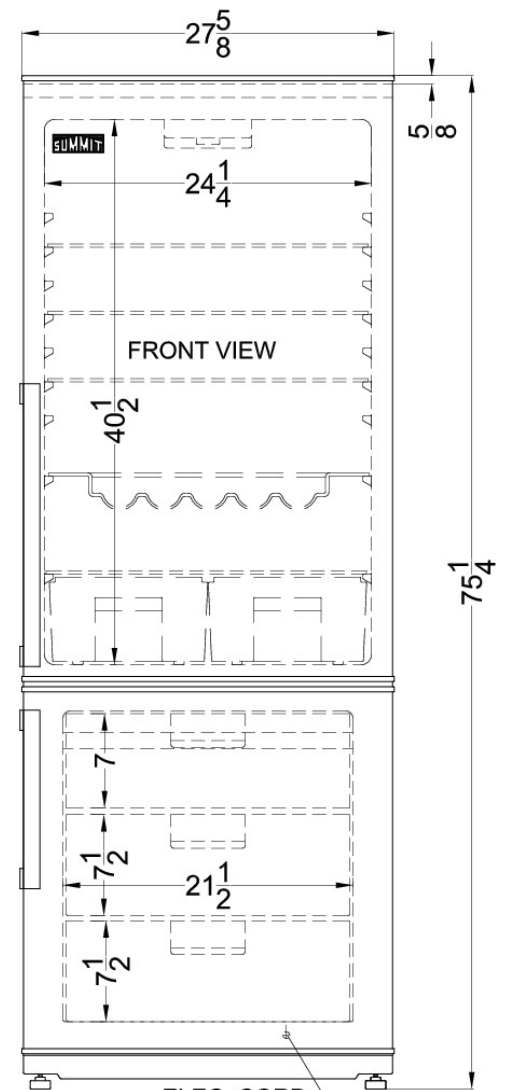
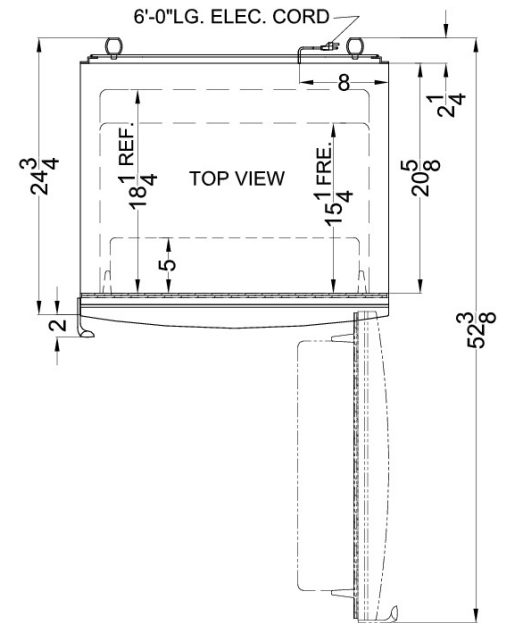

SUMMIT APPLIANCE DIVISION FELIX STORCH, INC.

770 Garrison Avenue, Bronx, NY 10474 USA TEL 718-893-3900 FAX 844-478-8799 info@summitappliance.com www.summitappliance.com